

DRINKS | Drink Cabinets

DRINK COOLER ▶ UPRIGHT COOLERS ▶ BLACK PAINTED



TKG 120B

CUSTOMIZATION AVAILABLE
PERSONALIZZAZIONE DISPONIBILE

35 mm	K1 +0°C +7°C	D ENERGY CLASS	CC2 +32°C 65RH
Key icon	Door icon	Light icon	GAS R600a
			LED

DETAILS

Lock fitted as standard	Digital Thermostat	Inner vertical LED light

GENERAL FEATURES

- 55 Lt. Upright drink cooler
- External in black coated plate, black thermoformed internally
- Roll-bond evaporator system with fan assisted cooling
- Automatic compressor cycle defrost
- Foaming Agent Cyclopentane (35mm per side)
- Digital Thermostat
- Inner vertical LED light
- Removable Gasket
- Adjustable shelves: 2 Pcs
- Self closing door and lock fitted as a standard
- Double layer safety tempered glass
- N.2 Adjustable feet + N.2 Rollers at the back
- Energy efficiency class: D

TECHNICAL SPECIFICATIONS

Capacity	88 L
Temperature	K1 (0°C-+7°C)
Consumption	1.33 kWh/24h
Rated Power	215 W
Noise level	42 dB(A)
Net Weight	38 Kg
Gross Weight	43 Kg
External Dimensions (WxDxH mm)	488x506x840
Internal Dimensions (WxDxH mm)	410x380x550
Packaging dimensions (WxDxH mm)	560x590x960
Loading quantities 20'/40'/40'HQ	80/160/160

PRODUCT DIMENSIONS

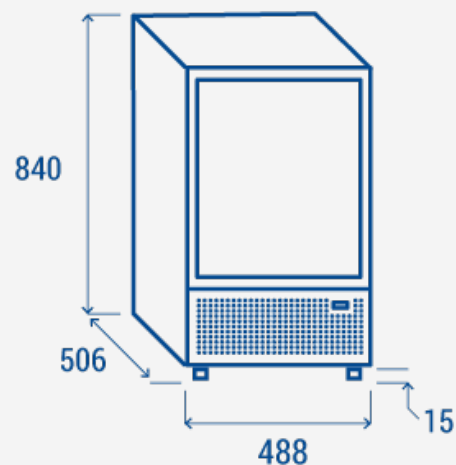

CERTIFICATION

CE RoHS

